

Dimensions

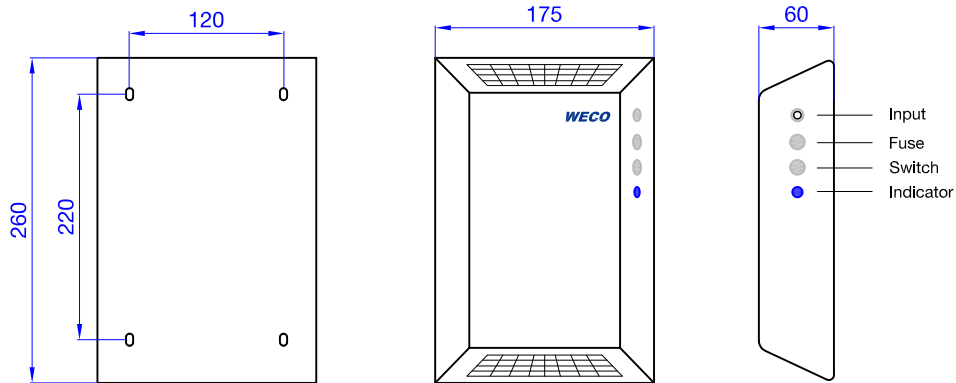

Material: painted midl steel RAL 7035

Installation

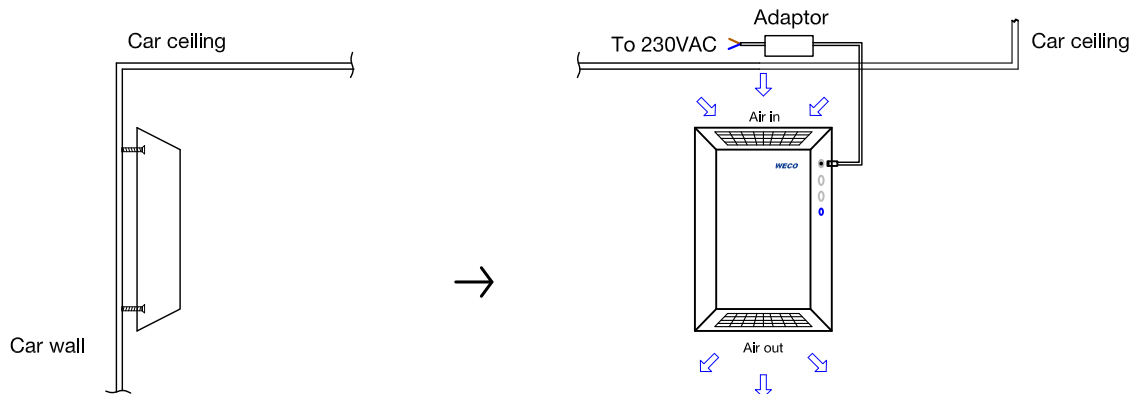

Packaging

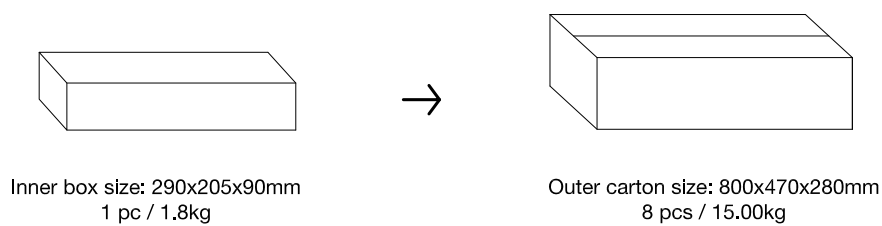

Specifications

Input voltage	220VAC±10%, 50/60Hz	Air volume	60m ³ / h	Noise	≤ 50dB
Working voltage	12VDC	Ion tube size	80mm	Filter type	Primary filter
Power	10W	Ion tube quantity	1pc	Working temp.	-20 to 60°C
Purifying area	20-30m ²	Ion tube life span	2 years	Storage temp.	-25 to 65°C

Production series	Elevator Disinfection	Edition No.	V3.20.05
Production code	X4-XD-AP10	Made by	Ken
TS No.	LK20.X1040	Approved by	Susan